

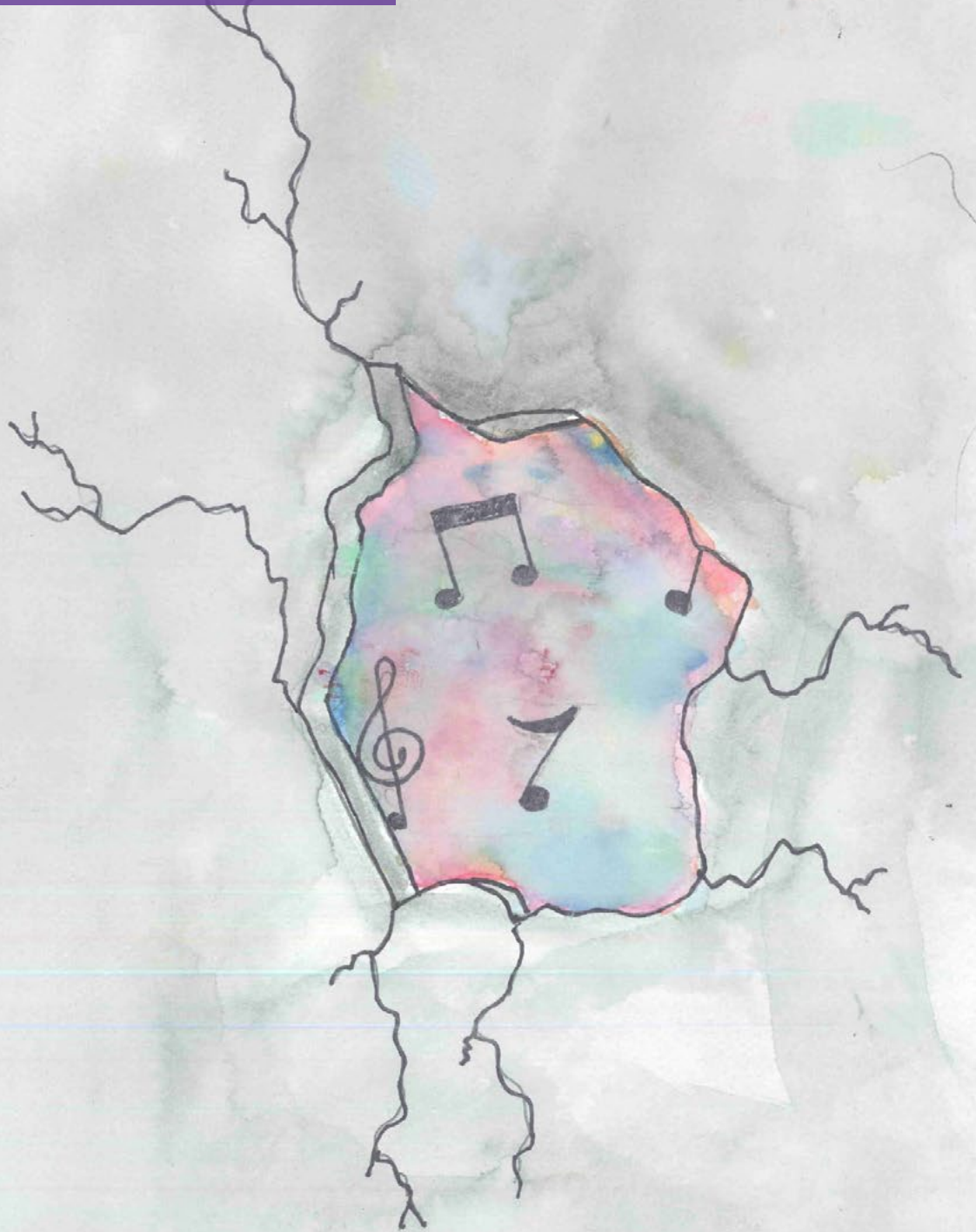

125 YEARS

NEW HAVEN SYMPHONY ORCHESTRA

**Program Notes for Kids**  
November 29 | Woolsey Hall



# BEETHOVEN!

Piano Concerto No. 4

Beethoven

Symphony No. 3, "Eroica"

Beethoven

## Welcome to the NHSO!

### Before the concert begins:

- Turn off any device that makes noise.
- Read the *Program Notes for Kids*.
- Locate the restrooms and exits.
- Look around at the architecture of the theater.
- Listen to musicians warm-up their instruments.

### During the concert:

- Clap as people enter the stage.
- Listen quietly as the orchestra plays.
- Wait for every section (called *movements*) of a piece to be played, then clap. (Hint: the conductor will turn to face you when it's time.)
- During intermission, you are free to get up.
- At the end of the concert, people may stand up to show their appreciation. This is called a *standing ovation*.



ENJOY!

# Instruments of the Orchestra



## Woodwinds

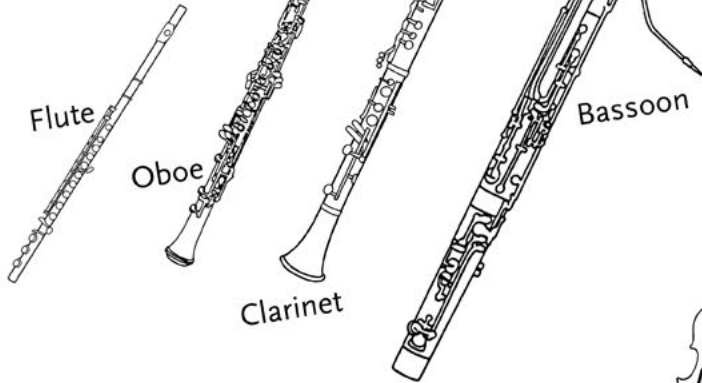

## Strings

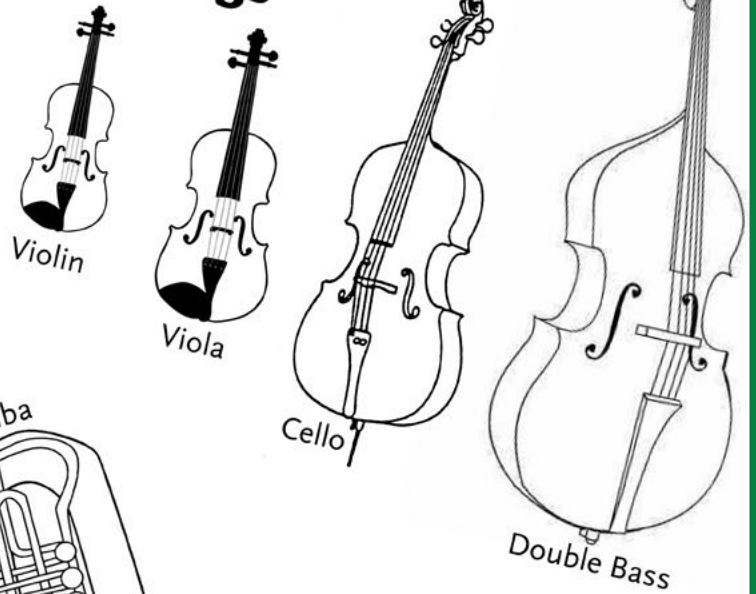

## Brass

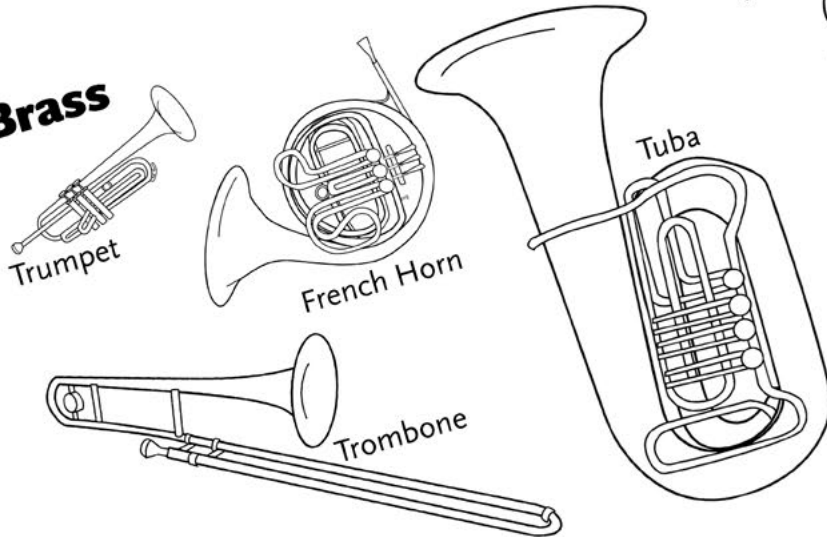

## Percussion

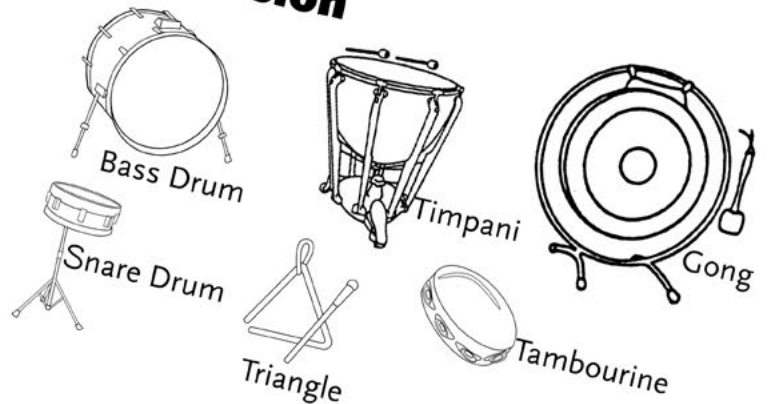

The orchestra is led by a conductor, sometimes called "maestro"

and more!



# WHO WAS BEETHOVEN?



**Ludwig van Beethoven** was born in Germany, somewhere around December 16th, 1770, although no one is really sure of the exact date. He began studying music at a very young age. When he first started playing, he had to stand on a stool to reach the keys of his piano.

Beethoven was almost as famous for his temper as he was for his music. He often got into arguments with his friends, family, and patrons. One time he tried to break a chair over the head of one of his most loyal patrons, Prince Lichnowsky. Another time, Beethoven stood in the doorway of Prince Lobkowitz's palace yelling, "Lobkowitz is a donkey!"

Despite his irritable personality, Beethoven is considered the greatest classical composer of all time. His masterpieces are still played all around the world. Much of his best works, like the famous Symphony No. 5, were written later in his life when he was almost completely deaf.

**Spotlight on:**

**Boris Berman**



Our star soloist tonight, Boris Berman, is an established concert pianist and head of the piano department at the Yale School of Music. He made his **debut**, or his first notable performance, when he was only seventeen!

Before teaching at Yale, Boris taught at the universities of Boston, Indiana, and Brandeis in the United States, as well as Tel-Aviv University in Israel.

Not only does Boris play piano, he has written two books: Notes From the Pianist's Bench and Prokofiev's Piano Sonatas: A Guide for the Listener and the Performer.

**What do you call a cow that plays the piano?**



**A moo-sician!**

# PIANO CONCERTO NO. 4

## Help! What's a concerto?!

A **concerto** is a piece of music, usually in three movements, written to have one musician (or a small group of them) play in front of an orchestra and show the audience all the cool things that their instrument(s) can do. At the end of the first movement, the entire orchestra will stop playing and the soloist will get to show off in front of the orchestra and audience. This is called a **cadenza**, and from time to time soloists even write their own. Sometimes, there's an extra cadenza in the third movement to give the soloist another chance to show off.

Normally, audiences aren't supposed to clap in between movements, but during some performances, people get so excited about how well the soloist played that they burst into applause at the end of the first movement!



Beethoven changed living situations so often that he had to transport his grand piano 37 times!

# SYMPHONY NO. 3, "EROICA"

Beethoven originally wrote Symphony No. 3, Eroica, or "Heroic Symphony", for Napoleon Bonaparte, leader of the French Revolution that was going on at the time. Beethoven admired Napoleon's anti-monarchy (anti-king) attitude. However, after Beethoven had already written Eroica, Napoleon declared himself Emperor of France, which went against everything Beethoven had liked about him. When Beethoven found out, he scratched out Napoleon's name on the title page so hard it made a hole in the paper! He ended up publishing the piece as Symphony Eroica, Composed to Celebrate the Memory of a Great Man. Beethoven intentionally used the word *memory* to make sure everyone knew that he no longer thought Napoleon was great!



Napoleon is known for being famously short, although that might not have been the case: His autopsy reported his height as 5'2", but that was likely in French inches. Other reports say he was around 5'7", which is the average height of a modern-day Frenchman.

# SCAVENGER HUNT

How many questions can you answer?

1. How many columns are there around Woolsey Hall? \_\_\_\_\_
2. How many organ pipes are there behind the stage? \_\_\_\_\_
3. How many french horns are on stage? \_\_\_\_\_
4. How many woodwind instruments are on stage? \_\_\_\_\_
5. How many lights are hanging from the ceiling? \_\_\_\_\_

If you were writing a review of Boris Berman's performance tonight, which words would you use to describe it? Check all that apply!

- |                                       |                                  |                                      |                                  |
|---------------------------------------|----------------------------------|--------------------------------------|----------------------------------|
| <input type="checkbox"/> Captivating  | <input type="checkbox"/> Boring  | <input type="checkbox"/> Effortless  | <input type="checkbox"/> Quick   |
| <input type="checkbox"/> Exhilarating | <input type="checkbox"/> Amazing | <input type="checkbox"/> Fascinating | <input type="checkbox"/> Vibrant |
| <input type="checkbox"/> Quiet        | <input type="checkbox"/> Fast    | <input type="checkbox"/> Fire        | <input type="checkbox"/> Slow    |

Are the beginning and ending of the movements in Beethoven's "Eroica" performed piano (softly) or forte (loudly)?

	<u>Beginning of Movement:</u>	<u>End of Movement:</u>
I. Allegro con brio	_____	_____
II. Marcia funebre: Adagio assai	_____	_____
III. Scherzo: Allegro vivace	_____	_____
IV. Finale: Allegro molto	_____	_____

Out of the two pieces that you heard tonight, which one did you like best? Why?

---

---

---

# CONCERT REVIEW

Write or draw about your experience at the concert tonight.

Who did you see? What did you hear?

What did you think about the music and the experience?

What would you like to tell the Maestro and the musicians?

We would love to know what you think!  
Scan or copy this page and send it to

Education Department  
4 Hamilton Street  
New Haven, CT 06511  
[Education@NewHavenSymphony.org](mailto:Education@NewHavenSymphony.org)





## Family Concert Series: FAIRY TALES

The NHSO Family Concert Series provides fun, interactive concerts for students ages 3-9 to meet the instruments of the orchestra. These concerts will be held from January - March at Davis Street School in New Haven and Shelton Intermediate School.

Before each concert, the NHSO offers an Instrument Petting Zoo where children can tap, tickle, and toot real orchestral instruments before the performance. Following the concert, families are invited to stay for a healthy snack. New Haven Reads provides free children's books for everyone who attends the concert. Attendance is FREE but donations are welcome!

**THREE BILLY GOATS GRUFF**  
January 9 & 10

The NHSO string quintet tells this classic fairytale while studying famous melodies.

**GREEN EGGS & HAM**  
February 23 & 24

Dr. Seuss's classic tale is told by NHSO fan favorite, Michael Boudewyns

**LITTLE RED RIDING HOOD TAKES METRO NORTH**  
March 9 & 10

A world premiere by the NHSO's mixed quartet!

Visit [NewHavenSymphony.org/Family](http://NewHavenSymphony.org/Family) to learn more.

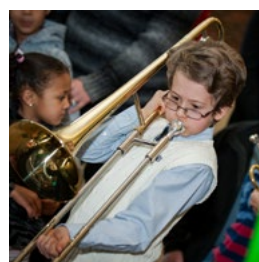
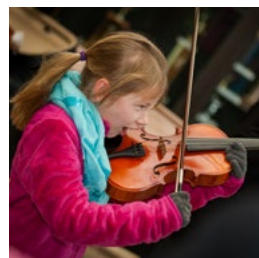

# Did you know?

## Kids go **FREE** to **ALL** NHSO concerts!

The NHSO offers free KidTix for children age 17 and under with the purchase of an adult ticket. Additional child tickets are available for \$10 each. KidTix can be purchased online or by calling the NHSO box office at 203.787.4282.

**Frontier**  
COMMUNICATIONS

[NewHavenSymphony.org](http://NewHavenSymphony.org)

