



NEW HAVEN SYMPHONY ORCHESTRA

Program Notes for Kids

September 26 | Woolsey Hall

Congratulations to tonight's
Art Contest Winner:
Lucy Jiang, Grade 5,
Beecher Road School

Mozart and Part!

Fratres for Violin
Arvo Part

Symphony No. 44
Joseph Haydn

-- INTERMISSION --

Air for Violin
Aaron J. Kernis

Symphony No. 38
Wolfgang Amadeus Mozart

Welcome to the NHSO!

Before the concert begins:

- Turn off any device that makes noise.
- Read the *Program Notes for Kids*.
- Locate the restrooms and exits.
- Look around at the architecture of the theater.
- Listen to musicians warm-up their instruments.

During the concert:

- Clap as people enter the stage.
- Listen quietly as the orchestra plays.
- Wait for every section (called *movements*) of a piece to be played, then clap. (Hint: the conductor will turn to face you when it's time.)
- During intermission, you are free to get up.
- At the end of the concert, people may stand up to show their appreciation. This is called a *standing ovation*.



ENJOY!

Instruments of the Orchestra



Woodwinds

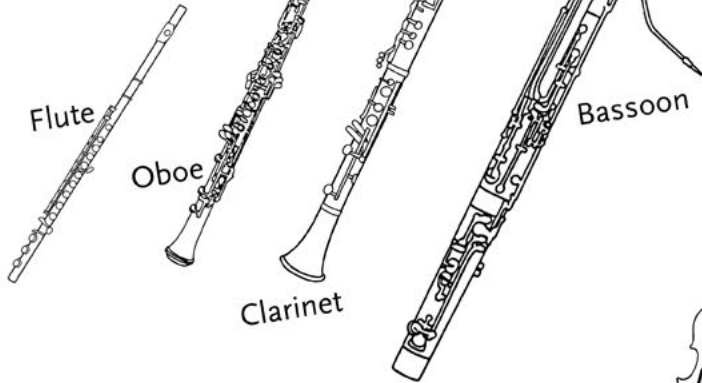

Strings

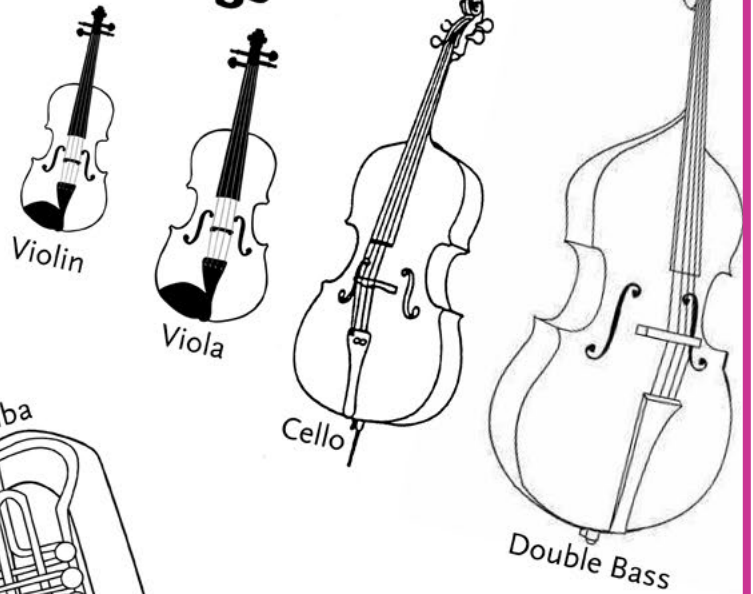

Brass

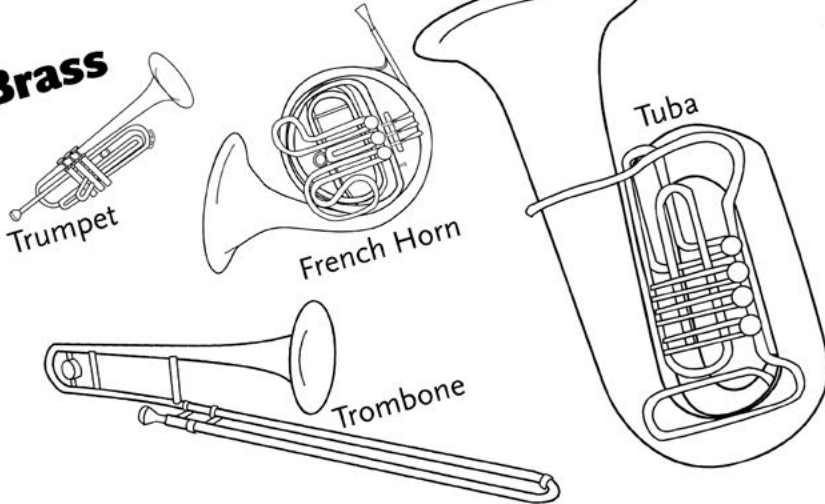

The orchestra is led by a conductor, sometimes called "maestro"

Percussion

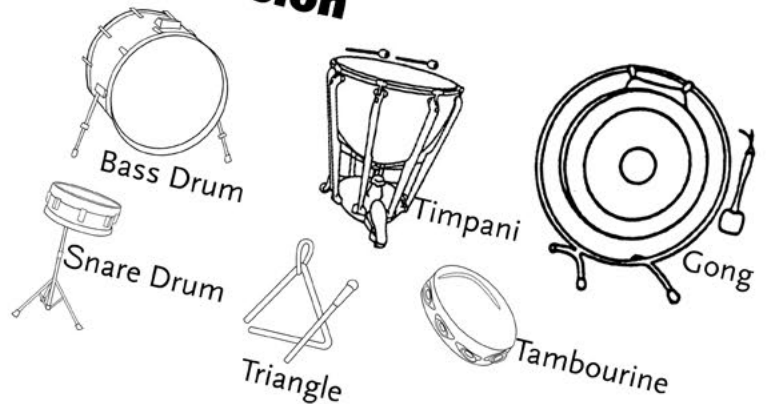

Tambourine
and more!

What is a Symphony?

A symphony is one piece of music that normally has four movements (kind of like chapters in a book). They usually sound different from one another: the first movement is fast, the second is slow, the third is medium/fast, and the last is fast again.

There are short pauses between movements. Usually, people don't clap then, but sometimes they get really excited and can't wait until the end of the whole piece to clap for the orchestra!

Spotlight on:

David Southorn



Violinist David Southorn is tonight's soloist on two pieces. Normally, he plays a very important role with the NHO - he is the concertmaster, or the lead violin who helps keep the group together and makes important decisions (with the Maestro) about how the violins will use their bows in different ways to make different sounds. He is ALSO the concertmaster for the Delaware Symphony Orchestra!

Make sure to clap loudly for him after his solos to show him how much you liked his playing!

Symphony No. 38

Mozart is one of the most famous composers of all time. His full name is **Johannes Chrysostomus Wolfgangus Theophilus Mozart!!** He began playing piano at age 4, after listening to his older sister, Nannerl, play the piano. The two of them also learned how to play violin. Both were considered **child prodigies**, or VERY talented musicians at a young age, and began playing for kings and queens when they were still very young. As he got older, Mozart became one of the leading composers of his day in operas, masses, symphonies, and concertos. You'll hear his 38th symphony tonight, nicknamed "The Prague" Symphony, because it was first performed in the city of Prague.



Symphony No. 44

Joseph Haydn wrote Symphony No. 44 in 1772. Haydn was born March 31st, 1732 in Rohrau, Austria. Haydn actually taught Beethoven; another famous composer; starting in 1792. Haydn was an assistant conductor for a real prince starting in 1761. He continued on to become Musical Director in 1766 when his previous boss passed away. He continued to do this work until his death in 1809. Because he taught so many younger composers, his nickname became "**Papa Haydn.**"



Fratres for Violin

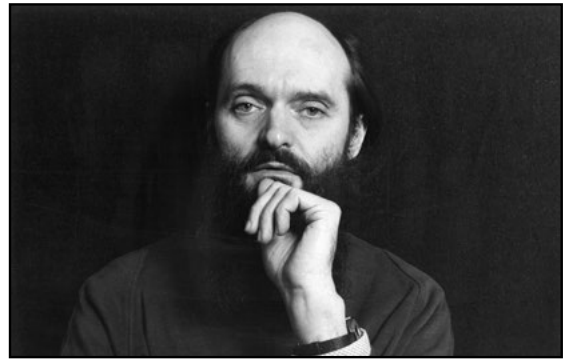

Arvo Part (pronounced Are-vo Peart) is a composer from the country of Estonia. He started composing in his 30s, but he played the oboe, percussion, and piano in the USSR Military Orchestra. He also worked as a sound engineer for the Estonian Radio. He wrote *Fratres* in 1977, and wrote it without telling anybody what instruments to play when playing the piece! So there have been many different versions recorded of this piece, because any combination of instruments can play it!

Air for Violin



Aaron J. Kernis was born on January 15th, 1960 in Philadelphia. He started on the violin and then at age twelve taught himself piano and composition. *Air for Violin* was composed in 1995 and is dedicated to his wife Evelyne Luest, who is a famous piano player. Even though it was played and written first for a piano player in front of an orchestra, it has been re-written many times for a different instrument (or even a group of instruments!) and orchestra. Kernis has taught composition at Yale school of Music (right here in New Haven!) since 2003.

SCAVENGER HUNT

How many questions can you answer?

1. How many columns are there around Woolsey Hall? _____
2. How many organ pipes are there behind the stage? _____
3. How many violins are on stage? _____
4. How many basses are on stage? _____
5. How many lights are hanging from the ceiling? _____

If you were writing a review of David Southorn's performance tonight, which words would you use to describe it? Check all that apply!

- | | | | |
|---------------------------------------|--------------------------------------|--------------------------------------|----------------------------------|
| <input type="checkbox"/> Captivating | <input type="checkbox"/> Boring | <input type="checkbox"/> Effortless | <input type="checkbox"/> Quiet |
| <input type="checkbox"/> Quick | <input type="checkbox"/> Mesmerising | <input type="checkbox"/> Loud | <input type="checkbox"/> Happy |
| <input type="checkbox"/> Exhilarating | <input type="checkbox"/> Amazing | <input type="checkbox"/> Fascinating | <input type="checkbox"/> Vibrant |

Are the beginning and ending of the piece in today's concert performed piano (softly) or forte (loudly)?

Beginning of Piece:

End of Piece:

- | | | |
|------------------------|-------|-------|
| I. Symphony No. 38 | _____ | _____ |
| II. Fratres for Violin | _____ | _____ |
| III. Symphony No. 44 | _____ | _____ |
| IV. Air for Violin | _____ | _____ |

Out of the four pieces that you heard tonight, which one did you like best?
Why?

CONCERT REVIEW

Write or draw about your experience at the concert tonight.

Who did you see? What did you hear?

What did you think about the music and the experience?

What would you like to tell the Maestro and the musicians?

We would love to know what you think! Scan or copy this page and send it to us:

Education Department
4 Hamilton Street
New Haven, CT 06511
Education@NewHavenSymphony.org



Family Concert Series: AROUND THE WORLD

The NHSO Family Concert Series provides fun, interactive concerts for students ages 3-9 to meet the instruments of the orchestra. These concerts will be held from January - March at Davis Street School in New Haven and Shelton Intermediate School.

Before each concert, the NHSO offers an Instrument Petting Zoo where children can tap, tickle, and toot real orchestral instruments before the performance. Following the concert, families are invited to stay for a healthy snack. New Haven Reads provides free children's books for everyone who attends the concert. Attendance is FREE but donations are welcome!

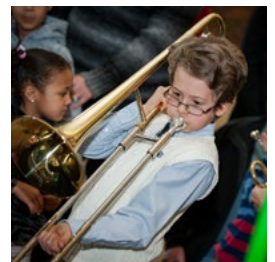

CHINA

January 18 & 19

Join erhu player Kevin Chen as we kick off Chinese New Year celebrations!

GHANA

February 1 & 2

We invited John Wesley Dankwa to share his home country of Ghana's music and culture.

PUERTO RICO

March 14 & 15

Guitarist Lorena Garay will introduce us to the rhythms and melodies from her home country, Puerto Rico.

Visit NewHavenSymphony.org/Family to learn more.

Did you know?

Kids go FREE to ALL NHSO concerts!

The NHSO offers free KidTix for children age 17 and under with the purchase of an adult ticket. Additional child tickets are available for \$10 each. KidTix can be purchased online or by calling the NHSO box office at 203.787.4282.

Frontier
COMMUNICATIONS

NewHavenSymphony.org